

ETA6002



2.5A, 3MHz Switching Charger with Dynamic Power Path in 8-pin ESOP

DESCRIPTION

ETA6002 is a switching Li-Ion battery charger with dynamic power-path control and input current limiting.

When a battery is connected, depending on the battery voltage, the DC-DC switching regulator either pre-conditions, fast-charges the battery or just regulates a system voltage (V_{SYS}) to a preset voltage. It does not require an external sense resistor

FEATURES

- ◆ Switching Charger with Power Path Management
- ◆ Up to 95% DC-DC Efficiency
- ◆ 50mΩ Power Path MOSFET
- ◆ Up to 2.5A Max charging current
- ◆ Instant on with a dead Battery or no Battery
- ◆ No battery detection
- ◆ No External Sense resistor
- ◆ Programmable Charging Current

for current sensing. The fast-charging current is determined by programming ISET pin. When the battery voltage reaches the termination voltage i.e. 4.2V, the charging path disconnects SYS to BATT. The ETA6002 also includes a dynamic power path when the SYS load current exceeds current limit of the DCDC regulator internally set, the SYS voltage falls below V_{BATT} , ETA6002 turns on the power-path to supplement the system load through the battery.

APPLICATIONS

- ◆ Tablet, MID
- ◆ Smart Phone
- ◆ Power Bank

ORDERING INFORMATION

PART	PACKAGE PIN	TOP MARK
ETA6002E8A	ESOP-8	ETA6002 YWWPL

TYPICAL APPLICATION

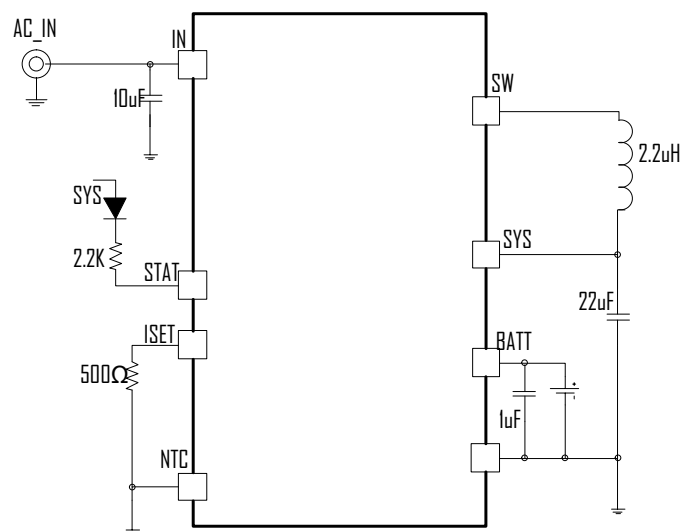

2A Switching Charger with Minimum Component Count

ETA6002

PIN CONFIGURATION

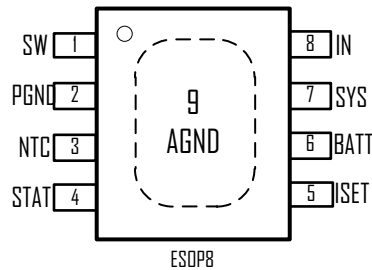

ABSOLUTEMAXIMUM RATINGS

(Note: Exceeding these limits may damage the device. Exposure to absolute maximum rating conditions for long periods may affect device reliability.)

IN, BATT Voltage	-0.3V to 6V
All Other Pin Voltage	$V_{IN} - 0.3V$ to $V_{IN} + 0.3V$
SW, SYS, BATT to ground current.....	Internally limited
Operating Temperature Range	-40°C to 85°C
Storage Temperature Range	-55°C to 150°C
Thermal Resistance	θ_{JA}
ESOP8.....	50°C/W

ELECTRICAL CHARACTERISTICS

($V_{IN} = 5V$, unless otherwise specified. Typical values are at $T_A = 25°C$.)

PARAMETER	CONDITIONS	MIN	TYP	MAX	UNITS
IN INPUT					
INPUT Range		4.4		5.5	V
INPUT UVLO	Rising, Hys=500mV		4.35		V
INPUT Operating Current	Switcher Enable, Switching		5		mA
	Switcher Enable, No Switching		70		µA
BATT to INPUT leakage Current	Input Floating		0	5	µA
DC-DC and SYS OUTPUT					
VSYSMIN	$I_{SYS} = 1A$, Default		3.6		V
VSYSMAX			4.5		V
Load Regulation			40		mV/A
Line Regulation	$V_{IN} = 4.75$ to $5.25V$		0.04		%/V
Switching Frequency			3		MHz
Max duty		100			%
HIGHSIDE MOS RDSON	$I_{SW} = 500mA$		100		mΩ
LOWSIDE MOS RDSON	$I_{SW} = 500mA$		60		mΩ
HIGHSIDE Current limit			3.5		A
SYS UVLO	Falling, Hys=200mV		2.25		V
Thermal Shutdown	Rising, Hys=30°C		160		°C
POWER PATH Management					
BATT TO SYS RDSON			50		mΩ
BATTERY CHARGER					
Battery CV voltage	$I_{BAT} = 0mA$, default	4.16	4.2	4.24	V
Charger Restart Threshold	From DONE to Fast Charge		-200		mV
Battery Pre-condition Voltage	V_{BAT} Rising Hys=180mV		2.9		V

Outperform with Efficiency

Proprietary Information DO NOT Distribute

2

ETA6002

PARAMETER	CONDITIONS	MIN	TYP	MAX	UNITS
			100		mA
AC Fast Charge Current	$R_{ISET1} = 500\Omega$, $nUSB_DET = V_{IN}$		2		A
Pre-condition Timer			120		min
Fast-Charge Timer			960		min
THERMISTOR MONITOR					
NTC Threshold, Cold	Charger Suspended		76.5		% V_{IN}
NTC Threshold, Hot	Charger Suspended		35		% V_{IN}
NTC Threshold Hysteresis			1.5		% V_{IN}
NTC Disable Threshold			100		mV
NTC Input Leakage			0		μ A
STATS					
STAT Output Low Voltage	$I_{STATS} = 10mA$			0.2	V

PIN DESCRIPTION

PIN #	NAME	DESCRIPTION
1	SW	Switching node of the Switching Regulator. Connect a $1\mu H$ to $2.2\mu H$ inductor from this pin to SYS
2	PGND	Power Ground Pin. Bypass with a $10\mu F$ capacitor to IN
3	NTC	Thermistor input
4	STATS	Status pin for Charging status indications. An open drain device capable of driving $10mA$ current
5	ISET	Fast Charge Current set pin. Connecting a Resistor between ISET to GND This sets the fast charge current value
6	BATT	Battery pin. Connect a Battery to this pin
7	SYS	System Voltage Pin. It is also the Switching regulator's output pin. Connect an inductor and capacitor to form the output filter
8	IN	Input pin. Can be connected to an AC adaptor or a USB charger output. Bypass with a $10\mu F$ capacitor each to PGND
9 (EP)	AGND	Exposed pad for analog ground connection. Must be connected to PGND on PCB

ETA6002

TYPICAL CHARACTERISTICS

(Typical values are at $T_A = 25^\circ\text{C}$ unless otherwise specified.)

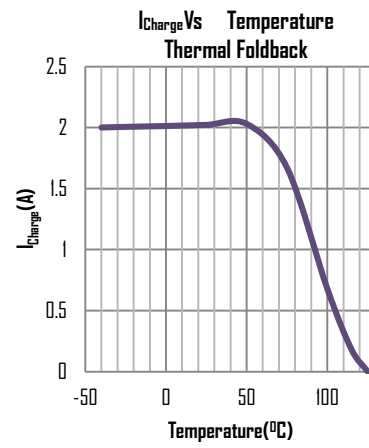
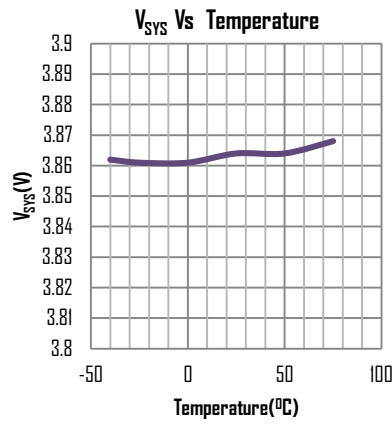
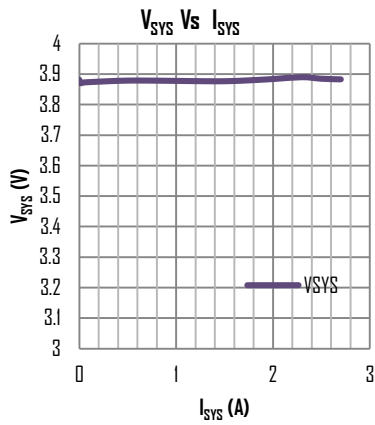
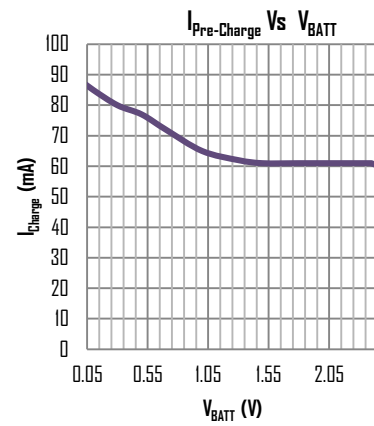
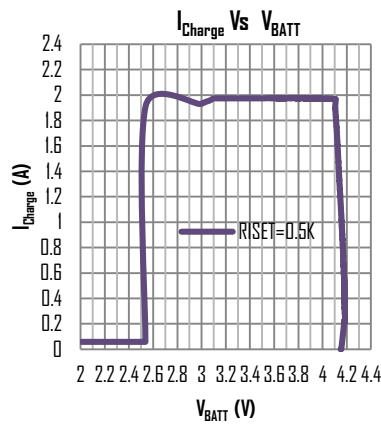
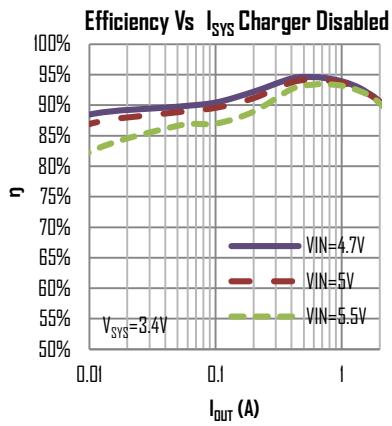

ETA6002

PACKAGE OUTLINE

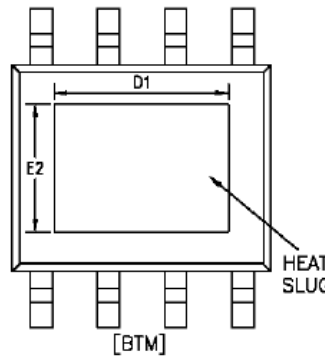
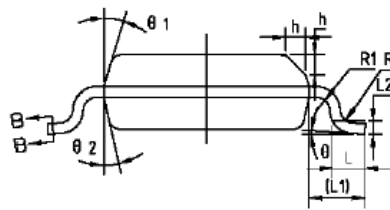
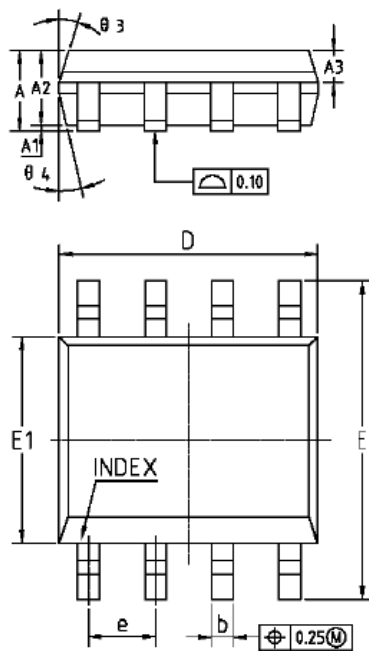

COMMON DIMENSIONS
(UNITS OF MEASURE=MILLIMETER)

SYMBOL	MIN	NOM	MAX
A	1.35	1.55	1.75
A1	0	0.10	0.15
A2	1.25	1.40	1.65
A3	0.50	0.60	0.70
b	0.35	-	0.51
b1	0.37	0.42	0.47
c	0.17	-	0.25
e1	0.17	0.20	0.23
D	4.80	4.90	5.00
D1	3.10	3.30	3.50
E	5.80	6.00	6.20
E1	3.80	3.90	4.00
E2	2.20	2.40	2.60
e	1.27BSC		
L	0.45	0.60	0.80
L1	1.04REF		
L2	0.25BSC		
R	0.07	-	-
R1	0.07	-	-
h	0.30	0.40	0.50
theta	0°	-	8°
theta 1	15°	17°	19°
theta 2	11°	13°	15°
theta 3	15°	17°	19°
theta 4	11°	13°	15°

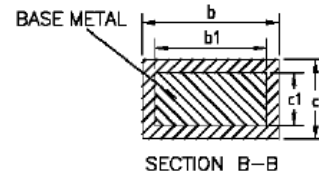

NOTES:
ALL DIMENSIONS REFER TO JEDEC STANDARD MS-012 AA
DO NOT INCLUDE MOLD FLASH OR PROTRUSIONS.